

Temperature Measurement 8 Chanel E710 Modbus RFID Reader



General Description

The FU0041 is a UHF Fixed Reader, designed with complete independent intellectual property rights. It combines proprietary efficient signal processing algorithms to maintain a high read rate while achieving rapid read and write processing of electronic tags. It can be widely used in various wireless radio frequency identification (RFID) systems such as logistics, access control systems, anti-counterfeiting systems, and production process control.

FEATURES

- Completely independently designed intellectual property;
- Operating frequency 865~868MHz/902 ~ 928MHz (adjustable according to different country or region requirements);
- Based on the IMPINJ E710 chip design, fully supporting electronic tags that comply with the 18000-6C (EPC C1G2) protocol standard; excellent multi-tag anti-collision function;
- Works in wideband frequency hopping (FHSS) or fixed frequency transmission mode;
- Output power up to 33dBm (adjustable);
- Reading distance up to 12M* (with an external 8dBi circular polarization antenna, tag E41);
- Supports RSSI;
- Tag inquiry speed* up to 1000 tags/sec;
- Tag cache area 1000 tags @ 96bit EPC;
- 8SMA antenna interfaces;
- Low power consumption design, +9V~+48V power supply;
- 1 solid state relay output (voltage output);
- RS485 (Modbus) communication;
- Supports Firmware online upgrade;
- Provides dynamic link library (DLL) and demo software source code, supports secondary development.

CHARACTERISTICS

- Absolute Maximum Ratings**

ITEM	SYMBOL	VALUE	UNIT
Power Supply	VCC	50	V
Operating Temp	T _{OPR}	-20~+60	°C
Storage Temp	T _{STR}	-20~+70	°C

- Electrical and Mechanical Specification**

Under T_A=25°C, VCC=+9V unless specified

ITEM	SYMBOL	MIN	TYP	MAX	UNIT
Power Supply	VCC	9	-	48	V
Current Dissipation	I _C	320 (5dBm)	-	1400(33dBm)	mA
Frequency	F _{REQ}	-	865~868(ETSI) 902~928(FCC)	-	MHz
RF Output Power	P _{RF}	5	-	33	dBm
Receive Sensitivity	SR	-	-87	-	dBm

INTERFACE

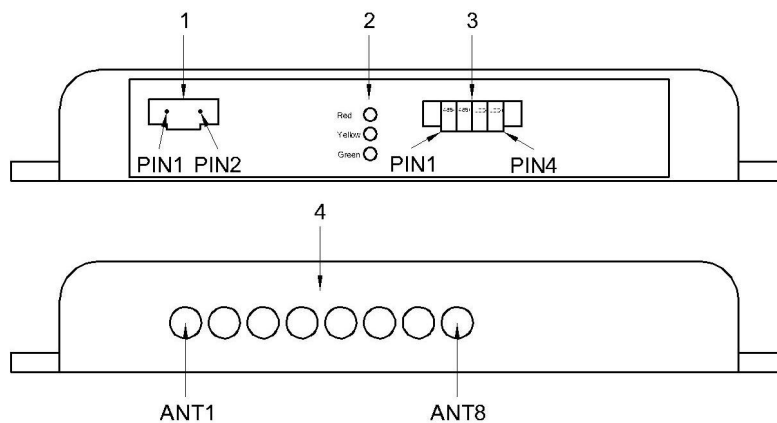

1. Power Interface

NO.	SYMBOL	COMMENT
1	GND	Ground
2	PWR	Power

2. Indicator Lights

NO.	SYMBOL	COMMENT
1	Red	Power indicator light
2	Yellow	Communication indicator light 1
3	Green	Communication indicator light 2

3. Communication Interface and Solid State Relay Output

NO.	SYMBOL	COMMENT
1	485-	RS485 communication+
2	485+	RS485 communication-
3	LED-	Connect to LED negative electrode
4	LED+	Connect to LED positive electrode

4. SMA Antenna Interface

MECHANICAL DATA (UNIT: mm)

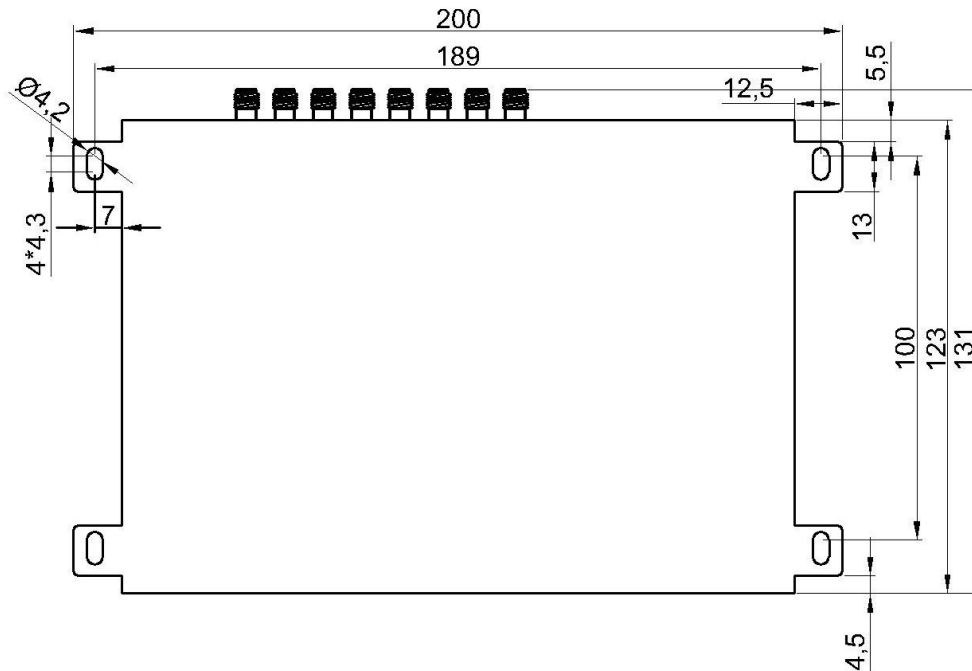

Accessories**Terminal block*1****Power adapter*1****Power cord*1**